

**Data sheet | Item number: 280-503/281-580**

Component terminal block; double-deck; with end plate; with gas-filled surge arrester; for DIN-rail 35 x 15 and 35 x 7.5; 2.5 mm<sup>2</sup>; CAGE CLAMP®

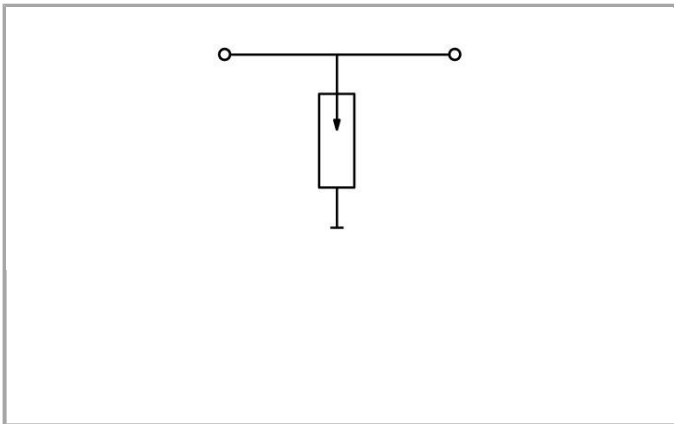

280-503/281-580

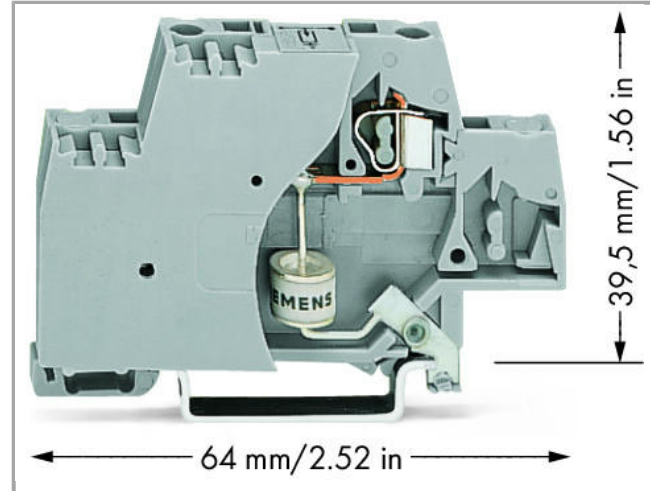
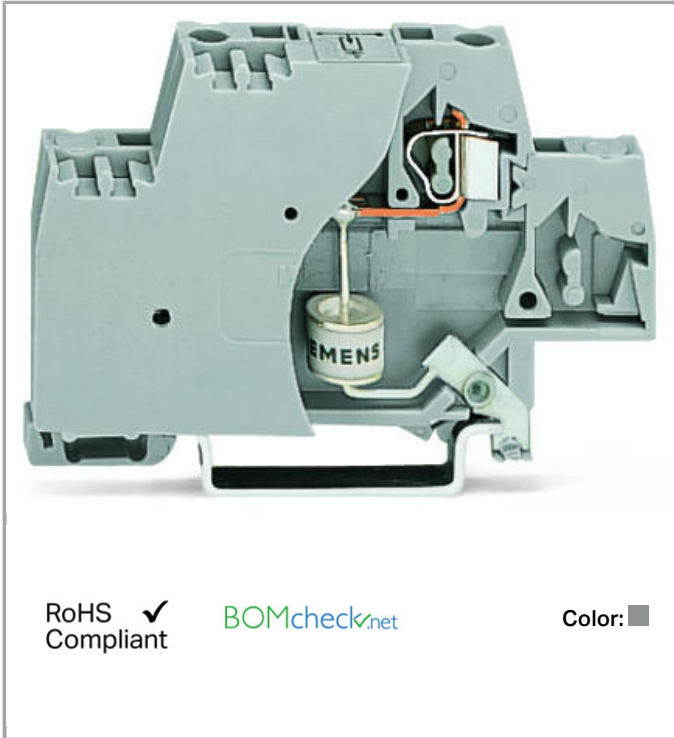

**Item description**

**Short description:**

Terminal blocks with surge suppression device and direct connection to the DIN-35 rail; these single-stage surge suppression devices are equipped either with 280 Series gas-filled surge arrester (coarse), varistor (medium) or suppressor diode (fine).

**Features:**

- Protect your system against overvoltage
-



- Slim, space-saving design
- Control operational costs by preventing expensive, unplanned downtime
- High operational reliability and system uptime

## Data

### Electrical data

Nominal operating voltage	AC/DC 115 V
Maximum continuous operating voltage	AC 180 V / DC 230 V
Rated continuous current	20 A
Nominal discharge current (8/20 µs) per line	5 kA
Voltage protection level (8/20 µs)	≤ AC 650 V
Response time line/line	≤
Capacitance	≤ 2 pF

### Connection data

Connections (number)	2
Connection technology	CAGE CLAMP®
Solid conductor	0.08 ... 2.5 mm <sup>2</sup> / 28 ... 14 AWG
Fine-stranded conductor	0.08 ... 2.5 mm <sup>2</sup> / 28 ... 14 AWG
Strip length	8 ... 9 mm / 0.31 ... 0.35 inch

### Geometrical Data

Width	10 mm / 0.394 inch
Height from upper-edge of DIN-35 rail	39.5 mm / 1.555 inch
Depth	64 mm / 2.52 inch

### Mechanical data

Design	With end plate; with direct connection to DIN rail
Type of mounting	DIN-35 rail

### Material Data

Color	gray
Fire load	0 MJ
Weight	12.316 g

### Commercial data













Product Group	1 (Rail Mounted Terminal Blocks)
Country of origin	DE
GTIN	4045454194277

Customs Tariff No.

8536901000

## Compatible products

## Marking accessories

	<b>Item no.: 2009-145</b> Mini-WSB Inline; for Smart Printer; on reel; stretchable 5 - 5.2 mm; plain; snap-on type		2009-145
	<b>Item no.: 2009-145/000-002</b> Mini-WSB Inline; for Smart Printer; on reel; stretchable 5 - 5.2 mm; plain; snap-on type	/000-002	2009-145
	<b>Item no.: 2009-145/000-005</b> Mini-WSB Inline; for Smart Printer; on reel; stretchable 5 - 5.2 mm; plain; snap-on type	/000-005	2009-145
	<b>Item no.: 2009-145/000-006</b> Mini-WSB Inline; for Smart Printer; on reel; stretchable 5 - 5.2 mm; plain; snap-on type	/000-006	2009-145
	<b>Item no.: 2009-145/000-007</b> Mini-WSB Inline; for Smart Printer; on reel; stretchable 5 - 5.2 mm; plain; snap-on type	/000-007	2009-145
	<b>Item no.: 2009-145/000-012</b> Mini-WSB Inline; for Smart Printer; on reel; stretchable 5 - 5.2 mm; plain; snap-on type	/000-012	2009-145
	<b>Item no.: 2009-145/000-023</b> Mini-WSB Inline; for smartPRINTER; on reel; stretchable 5 - 5.2 mm; plain; snap-on type	/000-023	2009-145
	<b>Item no.: 2009-145/000-024</b> Mini-WSB Inline; for Smart Printer; on reel; stretchable 5 - 5.2 mm; plain; snap-on type	/000-024	2009-145
	<b>Item no.: 248-501</b> Miniature WSB Quick marking system; plain; Marker width 5 mm; 10 strips with 10 markers per card		248-501
	<b>Item no.: 248-501/000-002</b> Mini-WSB marking card; as card; not stretchable; plain; snap-on type	/000-002	248-501
	<b>Item no.: 248-501/000-005</b> Mini-WSB marking card; as card; not stretchable; plain; snap-on type	/000-005	248-501
	<b>Item no.: 248-501/000-006</b> Mini-WSB marking card; as card; not stretchable; plain; snap-on type	/000-006	248-501



**Item no.: 248-501/000-007**  
Mini-WSB marking card; as card; not stretchable; plain; snap-on type

/000-007

248-501



**Item no.: 248-501/000-012**  
Mini-WSB marking card; as card; not stretchable; plain; snap-on type

/000-012

248-501



**Item no.: 248-501/000-017**  
Mini-WSB marking card; as card; not stretchable; plain; snap-on type

/000-017

248-501



**Item no.: 248-501/000-023**  
Mini-WSB marking card; as card; not stretchable; plain; snap-on type

/000-023

248-501



**Item no.: 248-501/000-024**  
Mini-WSB marking card; as card; not stretchable; plain; snap-on type

/000-024

248-501

#### Insulation stop



**Item no.: 280-470**  
Insulation stop; 0.08 - 0.2 mm<sup>2</sup> "s" (0.14 mm<sup>2</sup> "f-st"); 5 pieces/strip

280-470



**Item no.: 280-471**  
Insulation stop; 0.25 - 0.5 mm<sup>2</sup>; 5 pieces/strip

280-471



**Item no.: 280-472**  
Insulation stop; 0.75 - 1 mm<sup>2</sup>; 5 pieces/strip

280-472

#### End plate



**Item no.: 280-340**  
End and intermediate plate; 2.5 mm thick

280-340



**Item no.: 280-341**  
End and intermediate plate; 2.5 mm thick

280-341

#### Jumper



**Item no.: 280-482**  
Comb-style jumper bar; insulated; 2-way; IN = IN terminal block

280-482



**Item no.: 280-483**  
Comb-style jumper bar; insulated; 3-way; IN = IN terminal block

280-483



**Item no.: 280-484**  
Comb-style jumper bar; insulated; 4-way; IN = IN terminal block

280-484



**Item no.: 280-485**  
Comb-style jumper bar; insulated; 5-way; IN = IN terminal block

280-485



**Item no.: 280-490**  
Comb-style jumper bar; insulated; 10-way; IN = IN terminal block

280-490



**Item no.: 280-492**  
Alternate comb-style jumper bar; insulated; 2-way; IN = IN terminal block

280-492

#### tools

**Item no.: 210-720**



Operating tool with partially insulated shaft; Type 2, blade (3.5 x 0.5) mm

210-720

---

## Downloads

### Documentation

#### Additional Information

Disposal; Electrical and electronic equipment, Packaging	V 1.0.0	pdf 265.8 kB	Download
--	---------	-----------------	----------

---

## CAD/CAE - Smart Data

### CAD data

3D Download 280-503/281-580	URL	Download
-----------------------------	-----	----------

---

Subject to changes.

---